

INSTALLATION GUIDE FOR T8 (TYPE A+B)

This LED tube is intended to replace fluorescent tube lamps with ANSI designation 32W/T8/U6

THIS PRODUCT MUST BE INSTALLED IN ACCORDANCE WITH THE APPLICABLE INSTALLATION CODE BY A PERSON FAMILIAR WITH THE CONSTRUCTION AND OPERATION OF THE PRODUCT AND THE HAZARDS INVOLVED.

PLEASE REVIEW THE INSTRUCTIONS AND WARNINGS LISTED BELOW PRIOR TO PROPER INSTALLATION.

| WARNINGS | CAUTIONS |
|--|---|
| <ul style="list-style-type: none"> • WARNING - Risk of fire or electric shock. The electrical rating of these products are 120-277VAC, the installer must determine whether they have 120-277VAC at the luminaire before installation. • WARNING - Risk of fire or electric shock. LED Retrofit Kit installation requires knowledge of luminaires electrical systems. If not qualified, do not attempt installation. Contact a qualified electrician. • WARNING - Risk of fire or electric shock. Install this kit only in the luminaires that has the construction features and dimensions shown in the photographs and/or drawings and where the input rating of the retrofit kit does not exceed the input rating of the luminaire. • WARNING - To prevent wiring damage or abrasion, do not expose wiring to edges of sheet metal or other sharp objects. • Do not make or alter any open holes in an enclosure of wiring or electrical components during kit installation. • DO NOT USE WITH STANDARD DIMMERS. Only use the control provided with or specified by these instructions to control this lamp. This lamp will not operate properly when connected to a standard (incandescent) dimmer or dimming control. Suitable for damp locations. | <ul style="list-style-type: none"> • This device is not intended for use with emergency exits or not for emergency lighting. • Installers should not disconnect existing wires from lampholder terminals to make new connections at lampholder terminals. Instead installers should cut existing lampholder leads away from the lampholder and make new electrical connections to lampholder lead wires by using applicable wire connectors. • WARNING: To avoid potential fire or shock hazard, do not use this retrofit kit in luminaires employing shunted bi-pin lampholders. Note: Shunted lamp holders are found only in fluorescent luminaires with Instant-Start ballasts. Instant-start ballasts can be identified by the words "Instant Start" or "I.S." marked on the ballast. This designation may be in the form of a statement pertaining to the ballast itself, or may be combined with the marking for the lamps with which the ballast is intended to be used, for example F40112/IS. For more information, contact the LED luminaire retrofit kit manufacturer. • Installers should examine all parts that are not intended to be replaced by the retrofit kit for damage and replace any damaged parts prior to installation of the retrofit kit. |

T8 DIRECT REPLACEMENT/PLUG & PLAY INSTALLATION INSTRUCTIONS (TYPE A)

INSTRUCTIONS

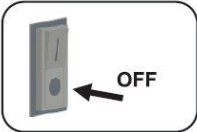

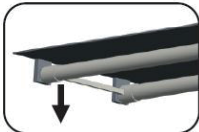

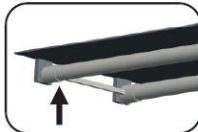

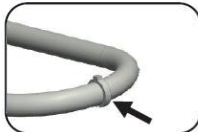

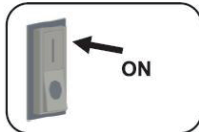

1. Switch-off power to the luminaire.
2. Remove fixture diffuser if present.
3. Remove the existing fluorescent lamps from your fixture.
4. Install the LED T8 U-Bend replacement lamp.
5. Attach the diffuser and turn on the power switch to the fixture.

T8 BALLAST BYPASS INSTALLATION INSTRUCTIONS (TYPE B)

THE RETROFIT KIT IS ACCEPTED AS A COMPONENT OF A LUMINAIRE WHERE THE SUITABILITY OF THE COMBINATION SHALL BE DETERMINED BY AUTHORITIES HAVING JURISDICTION.

PRODUCT MUST BE INSTALLED BY A QUALIFIED ELECTRICIAN IN ACCORDANCE WITH THE APPLICABLE AND APPROPRIATE ELECTRICAL CODES. THE INSTALLATION GUIDE DOES NOT SUPERSEDE LOCAL OR NATIONAL REGULATIONS FOR ELECTRICAL INSTALLATIONS.

BYPASSING MAGNETIC/ELECTRONIC BALLAST

- 1.** Turn-off power before installation.

OFF

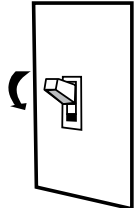

2. Remove the existing ballast and existing starter (if present) from the fixture.

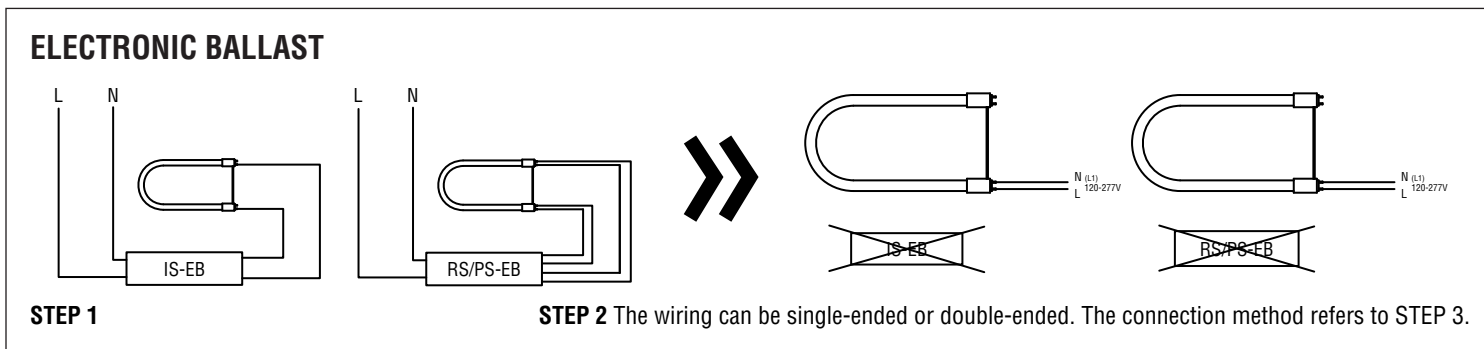
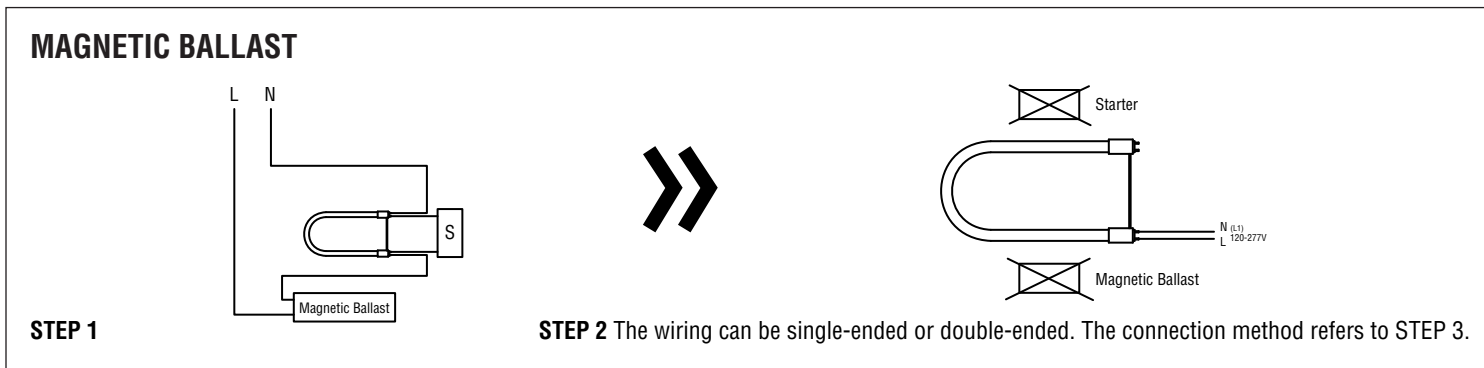

3. Rewire the fixture to be single-ended/double-ended power.

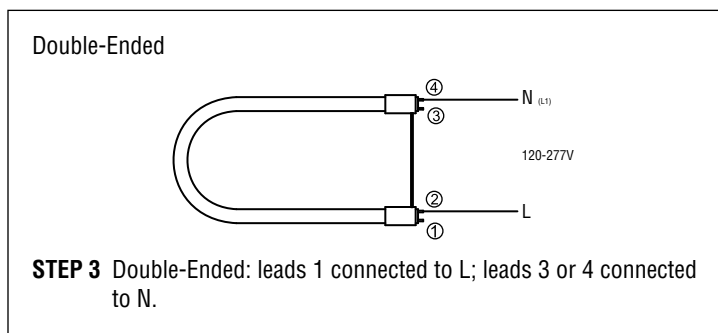
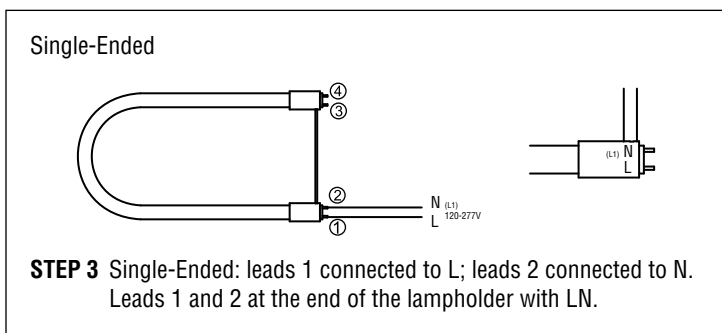

CAUTION: Use only non-shunted lampholders for Single-Ended wiring installations. Do not perform Single-Ended wiring installation of product in a fixture with shunted lampholders (found in all fixtures using instant start ballasts). If the existing lampholders are shunted, and Single-Ended wiring is desired, remove and replace them with non-shunted lampholders (or remove the external shunt if applicable). Make new connections directly to lampholder terminals as shown in Figure 1 below.

Typical Non-Shunted Lampholder

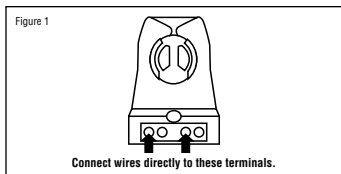

If it is non-shunted socket, it can work in both single-ended and double-ended.

Typical Shunted Lampholder

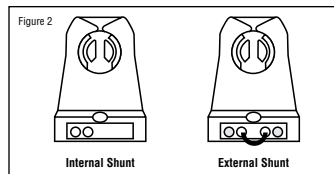

If it is shunted socket, it is double-ended only.

After wiring modification is completed, attach the replacement cautionary label onto a visible place on the fixture that is kept visible after installation of LED U-Bend.

⚠ WARNING!

USE LED LAMPS ONLY. THIS LUMINAIRE HAS BEEN MODIFIED TO USE LED LAMPS AND CAN NO LONGER OPERATE THE ORIGINALLY INTENDED LED U-BEND SAFELY.

LED U-BEND COULD BREAK AND CAUSE PERSONAL INJURY IF USED IN THIS FIXTURE.

Remove any pre-existing labels and replace them with the labels provided with this product.

SAVE THESE INSTRUCTIONS

4. Install the LED U-Bend.

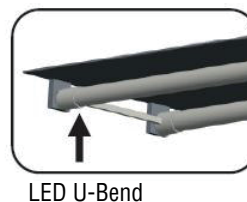

5. Turn-on the power and enjoy your LED U-Bend.