

PROJECT NAME: \_\_\_\_\_ CAT. #: \_\_\_\_\_  
 NOTES: \_\_\_\_\_ FIXTURE SCHEDULE: \_\_\_\_\_

## PurAirMax Tabletop Air Purifier



### Features

- H13 True HEPA filter (Maxlite model# APF-H13) included with Air Purifier
- 5.2 ft 18AWG x2 black power cord with NEMA 1-15P plug included
- Traps at least 99.97% of airborne allergens, dust and smoke particles
- Built-In timers set the air purifier to run for a specific amount of time
- 4 fan speeds - Sleep, Low, Medium and High
- Sleep mode runs the air purifier on the lowest and quietest setting
- Display screen can be turned off for optimized rest
- Display lock prevents current settings from being changed
- Meets California ozone emissions limit. CARB certified.

### Warranty

- 1 year standard.

### Ordering Information

ORDER CODE	MODEL NUMBER	ENERGY STAR PRODUCT ID
110330	AP215SF2	2545635

Replacement Part (Sold Separately)

ORDER CODE	MODEL NUMBER	DESCRIPTION	IMAGE
109487	APF-H13	Replacement filter with hepa and carbon h13 for use with air purifier	

### Specifications

	AP215SF2
<b>RATED POWER</b>	High Speed: 45W Middle Speed: 29W Low Speed: 19W Sleep Mode: 14W  (Standby power <0.5W)
<b>INPUT VOLTAGE</b>	120V AC, 60Hz
<b>ELECTRICAL APPLIANCE CATEGORY</b>	Class II
<b>ROTATE SPEED</b>	High Speed: 2200 rpm Middle Speed: 1500 rpm Low Speed: 1150 rpm Sleep Mode: 950 rpm
<b>AIR CHANGES PER HOUR (ACH) *</b>	Room Size: 178 ft2, ACH: 5; Room Size: 445 ft2, ACH: 2
<b>SMOKE TEST PARTICULATE: CADR</b>	115 ft3/ min
<b>DUST TEST PARTICULATE: CADR</b>	136 ft3/ min
<b>POLLEN TEST PARTICULATE: CADR</b>	157 ft3/ min
<b>SMOKE CADR WATT</b>	2.5 ft3/W
<b>CADR/ EFFECTIVE AREA</b>	128 CADR/ 178 ft2
<b>HIGH VOLTAGE INSULATION TEST</b>	2500V/ 5mA/ 1 min
<b>NOISE LEVEL</b>	Max. 60 dBA
<b>TIMER FUNCTION</b>	8 hours
<b>PURIFIER TYPE</b>	Composite/ Passive Type
<b>FILTER LIFE</b>	1500 hours
<b>HOUSING MATERIAL</b>	ABS Plastic
<b>FINISH</b>	White/Black
<b>NET WEIGHT</b>	8.2 lbs
<b>OPERATING TEMPERATURE</b>	41°F to 86°F
<b>CERTIFICATIONS</b>	ETLus Listed, ES, FCC
<b>MATERIAL USAGE</b>	RoHS compliant, no mercury
<b>WARRANTY</b>	1 year standard warranty

\* Based on 5 air changes per hour (ACH). Effective for larger rooms but purification will take longer.



1-year standard warranty (further details available at [www.maxlite.com/warranties](http://www.maxlite.com/warranties)).

## PurAirMax Tabletop Air Purifier

### Dimensions

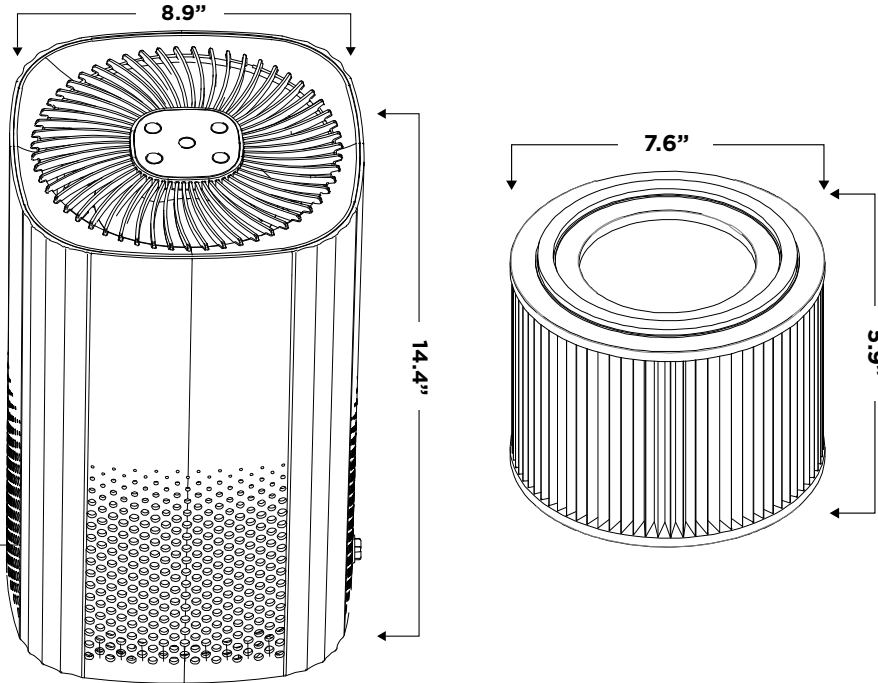

MODEL	H (INCH)	W (INCH)
AP215SF2	14.4 (Overall)	8.9
APF-H13	5.9 (Overall)	7.6

### Display Screen Functions

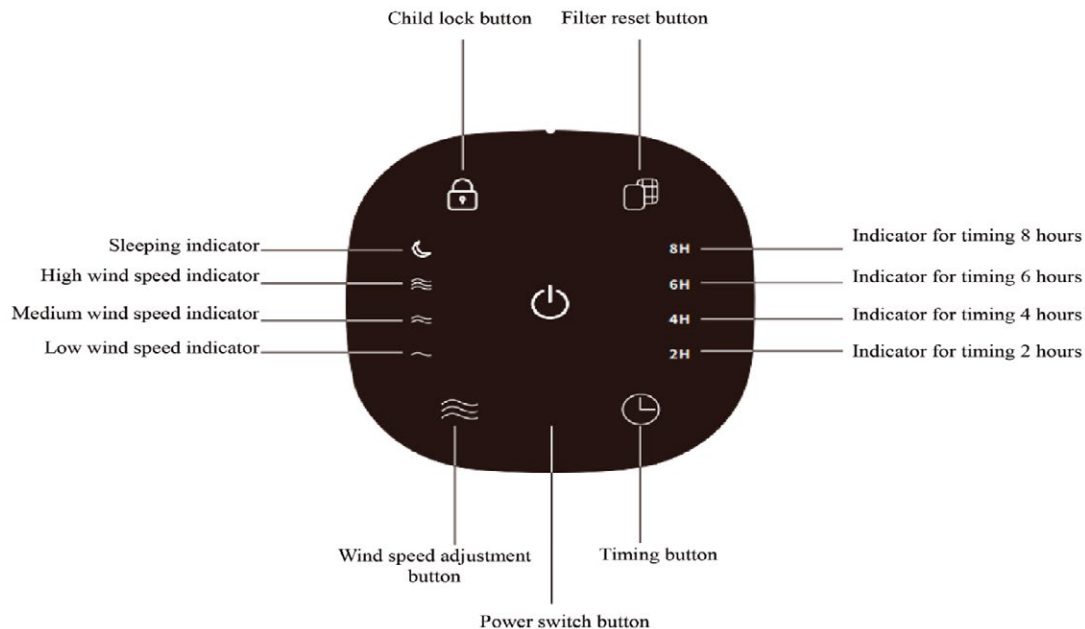

### FCC Statement

NOTE: This equipment has been tested and found to comply with the limits for a Class B digital device, pursuant to Part 15 of the FCC Rules. These limits are designed to provide reasonable protection against harmful interference in a residential installation. This equipment generates, uses and can radiate radio frequency energy and, if not installed and used in accordance with the instructions, may cause harmful interference to radio communications. However, there is no guarantee that interference will not occur in a particular installation.